

**LEGEND**

- \* - TREE VIOLATION
- \* - TREE (NON VIOLATION)
- △ - SURVEY REFERENCE POINT
- - UTILITY POLE
- - OBSTACLE LIMITATION SURFACE
- 970 - D.L.S. ELEVATION
- - D.L.S. CONTOUR

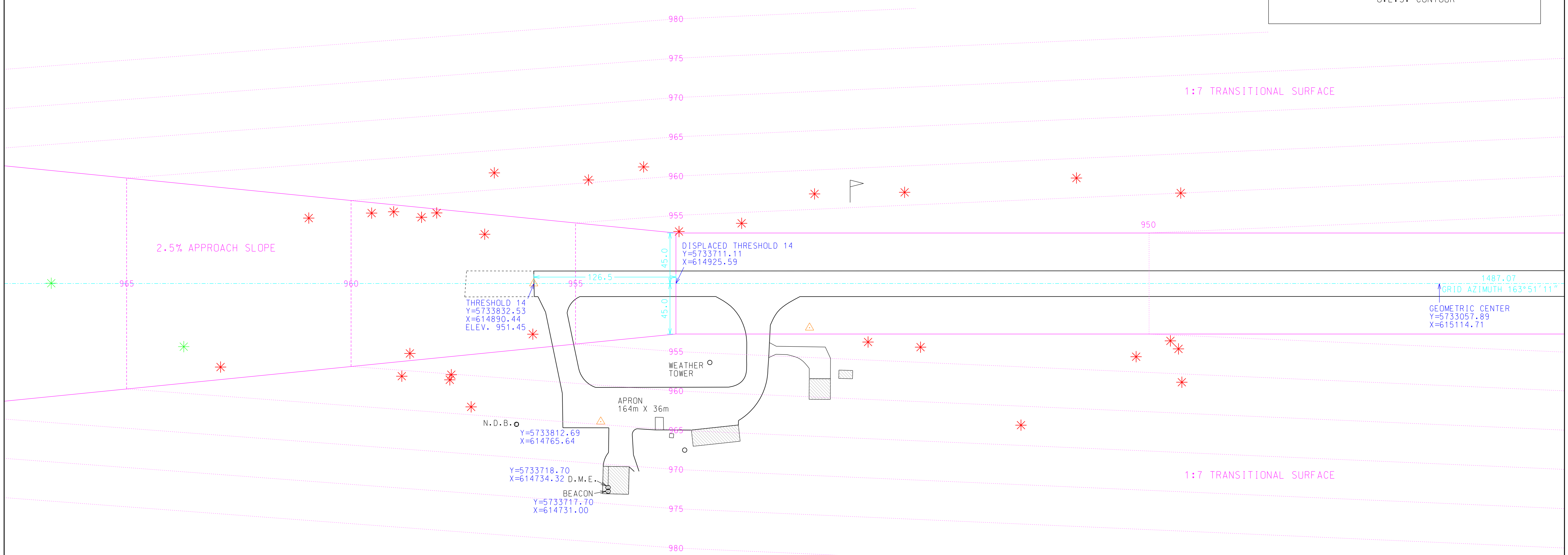

**NOTES:**

- COORDINATES SHOWN ARE U.T.M. ZONE 10.
- TO CALCULATE GROUND DISTANCES DIVIDE GRID DISTANCE BY COMBINED SCALE FACTOR 0.9996147.
- SURVEY DATE JUNE 2008 - J. HAY
- ELEVATIONS ARE GEODETIC REFERRED TO BENCH MARK 82C075.
- 2008 MAGNETIC DECLINATION: 18°17' EAST

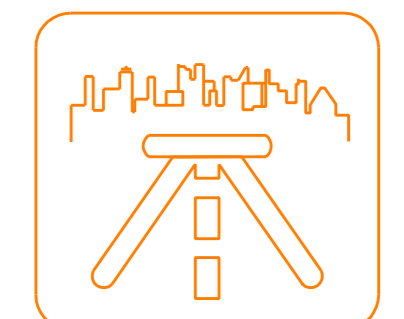
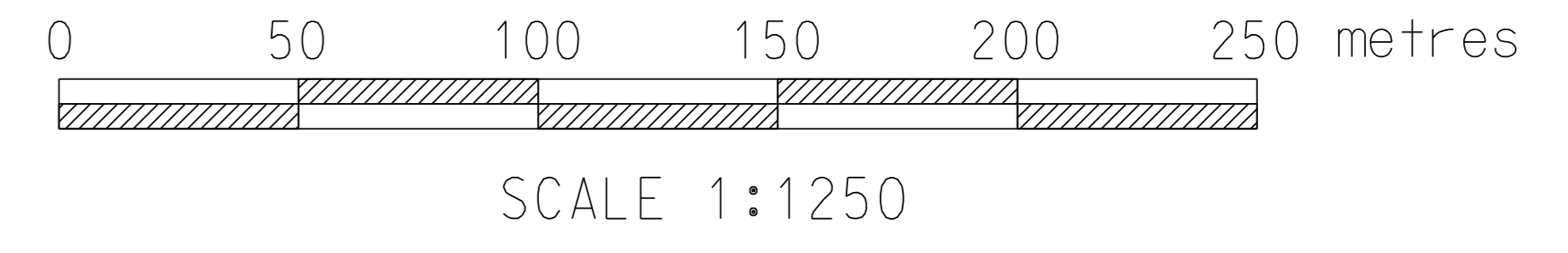

**Skyline Surveys**

plotting date: 2008/06/11	revised by: -----
drawn by: J. HAY	sheet no: 1 of 2

108\_MILE\_AIRPORT\_  
AERODROME\_SURVEY\_PLAN\_

108Mile08-2d+ .dgn

...108Mile\108Mile08-2d+.dgn 6/12/2008 11:41:34 AM