

LEGEND

- * - TREE VIOLATION
- * - TREE (NON VIOLATION)
- △ - SURVEY REFERENCE POINT
- - UTILITY POLE
- - OBSTACLE LIMITATION SURFACE
- 970 - D.L.S. ELEVATION
- - D.L.S. CONTOUR

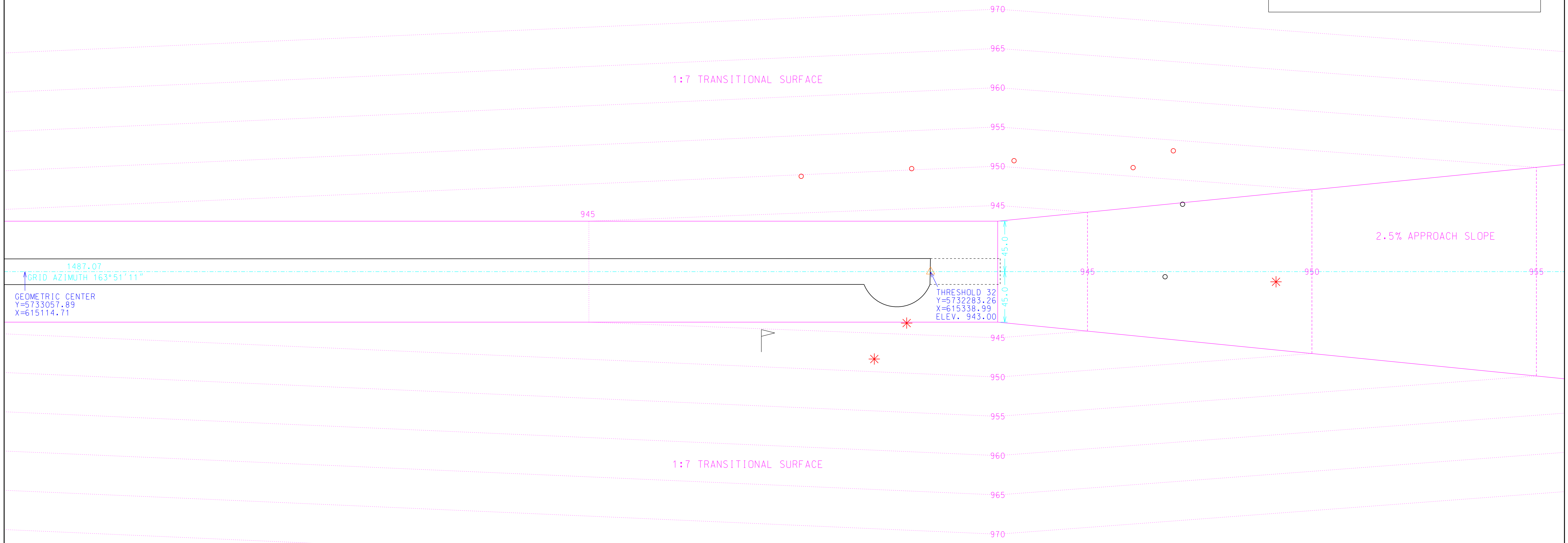

1487.07
GRID AZIMUTH 163°51'11"

GEOMETRIC CENTER
Y=5733057.89
X=615114.71

- NOTES:**
- COORDINATES SHOWN ARE U.T.M. ZONE 10.
 - TO CALCULATE GROUND DISTANCES DIVIDE GRID DISTANCE BY COMBINED SCALE FACTOR 0.9996147.
 - SURVEY DATE JUNE 2008 - J. HAY
 - ELEVATIONS ARE GEODETIC REFERRED TO BENCH MARK 82C075.
 - 2008 MAGNETIC DECLINATION: 18°17' EAST

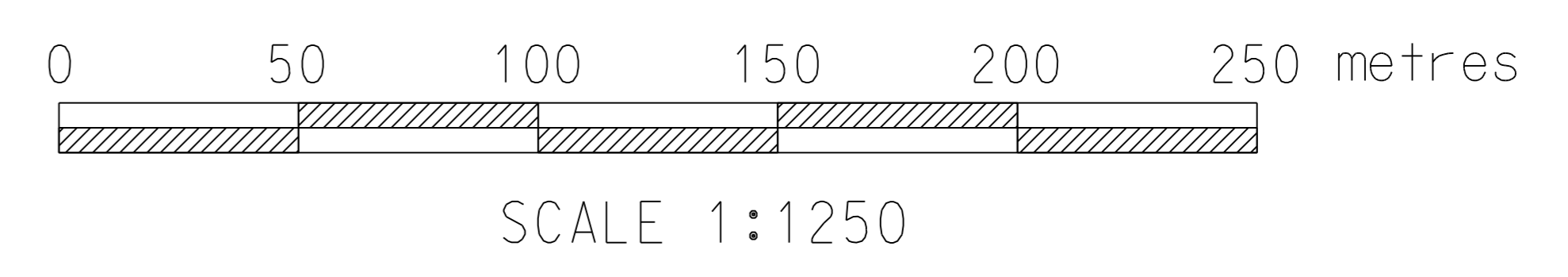

Skyline Surveys

plotting date: 2008/06/12	revised by: _____
drawn by: J. HAY	sheet no: _2 of _2

108_MILE_AIRPORT_
SURVEY_PLAN_

108Mile08-2d+ .dgn

...108Mile\108Mile08-2d+.dgn 6/12/2008 11:42:36 AM